

GCT 3-14

TELESCOPIC HANDLER

GEHL®



KEY FEATURES

- Multi-Function Joystick on Floating Armrest
- Automatic Parking Brake
- Harmony Display
- Polycarbonate Roof Window
- Hydrostatic Transmission, 2-Speed
- 3 Steering Modes
- Articulated Rod
- Battery Cut-Off

GCT 3-14 TELESCOPIC HANDLER

SPECIFICATIONS

	IMPERIAL	METRIC	
DIMENSIONS	Minimum Shipping Mass	5622 lbs	2550 kg
	Maximum Shipping Mass	6063 lbs	2750 kg
	Ground Clearance	11.4"	290 mm
	Wheelbase	83.9"	2130 mm
	Overall Length to Carriage (with hitch)	136.6"	3470 mm
	Front Overhang	30.3"	770 mm
	Overall Width	58.7"	1490 mm
	Overall Cab Width	26"	655 mm
	Overall Height	75.6"	1920 mm
	Tilt-down Angle	116°	
	Tilt-up Angle	23°	
	External Turning Radius (over tires)	103.1"	2620 mm
CAPACITIES	Maximum Capacity	2758 lbs	1250 kg
	Maximum Lifting Height	169.3"	4300 mm
	Maximum Outreach	103.1"	2620 mm
	Reach at Maximum Height	39.4"	1000 mm
	Breakout Force with Bucket	1880 daN	
ENGINE	Engine Brand	Yanmar	
	Engine Norm	Stage V / Tier 4 Final	
	Engine Model	3TNV88C - DMU	
	Number of Cylinders	3	
	Capacity of Cylinders	646.5 in ³	1642 cm ³
	I.C. Engine Power Rating / Power	35.10 hp	26.20 kW
	Maximum Torque / Engine Rotation @ 1950rpm	105 ft/lbs	105 Nm
	Drawbar Pull (Laden)	2000 daN	
OTHER	Hydraulic Pump Type	Gear Pump	
	Hydraulic Pressure	3408 PSI	235 bar
	Hydraulic Flow	12.7 gal/min	48 L/min
	Maximum Travel Speed	15.5 mph	25 km/hr
	Fuel Tank Capacity	9.2 gal	35 L
	Hydraulic Oil Tank Capacity	10.3	39 L
	Standard Tires	CAMSO - MPT 552 10.0/75-15.3 124A8	

GEHL Company reminds users to read and understand the operator's manual before operating any equipment. Also, make sure all safety devices and shields are in place and functioning properly.

GEHL reserves the right to add improvements or make changes in specifications at any time without notice or obligation.

STANDARD FEATURES

- Hydrostatic Transmission, 2-Speed
- Articulated Rod
- Multi-Function Joystick on Floating Armrest
- Automatic Parking Brake
- Double Switch Buttons (DSB)
- Harmony Display
- USB Plug
- Document Net
- Polycarbonate Roof Window
- Battery 12V-110Ah-750A
- Battery Cut-Off
- Fixed Towing Hook
- Tilting Carriage Cut-Off
- Front Mudguards
- Connected Machine
- 4-Wheel Drive
- 3 Steering Modes
- Front and Rear Wheel Alignment Indicators

OPTIONAL FEATURES

- Attachment Hydraulic Line + ECS
- Attachment Hydraulic Locking
- Air Suspension Cloth-Covered Seat
- Adjustable Steering Column
- Air Conditioning
- Stop & Start
- Air Pre-Filter
- Auto-Reversing Fan
- Continuous Flow Hydraulics
- LED Road Lights
- LED Work Lights on Cab (x4)
- LED Boom Work Lights (x2)

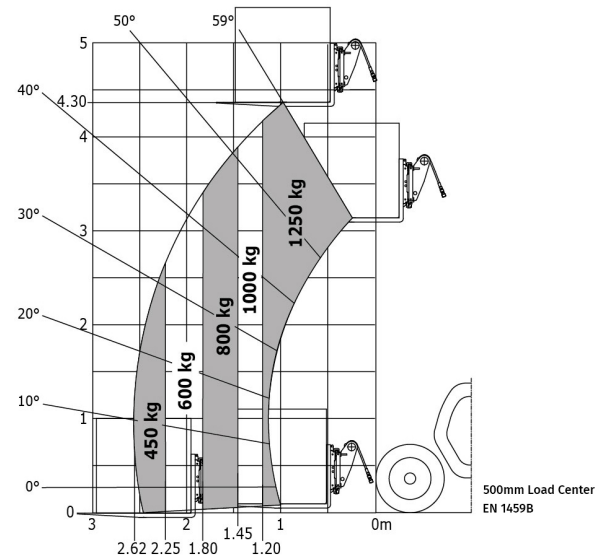

GEHL COMPACT EQUIPMENT

West Bend, WI 53095 U.S.A. | Tel: 262-334-9461 | Fax: 262-338-7517